



Quality of Place and Personnel

Budget Presentation

November 7, 2023



Budget Calendar

- Tonight is the third of five formal presentations on the 2024 Budget.
- Upcoming Presentations/Workshops
 - **November 21, 2023** – Economic Health/Development, Budget Overview. Public Hearing
 - **November 28, 2023** – Check in w/Council
 - **December 5, 2023** – Continued Public Hearing

Presentation Agenda

1. Quality of Place and Community Wellness
 - a. Fruita Community Center Fund
 - b. Parks and Recreation Budget Highlights
 - c. Public Safety Overview
2. Personnel and Employee Retention

Quality of Place – Fruita Community Center Budget Highlights

- **Overview**

- The Community Center is funded through user fees and tax revenues.
- Through October, FCC has had 159,000 visitors, trending ahead of 2022, slightly below 2019.



Quality of Place – Fruita Community Center Budget Highlights

- 2024 Revenues
 - \$3.9 Million
 - Decrease of 2% over 2023 estimated revenues.
 - Decrease due to one-time revenues received in 2023 (insurance payments, grants).

2024 Revenues - \$3.9 million

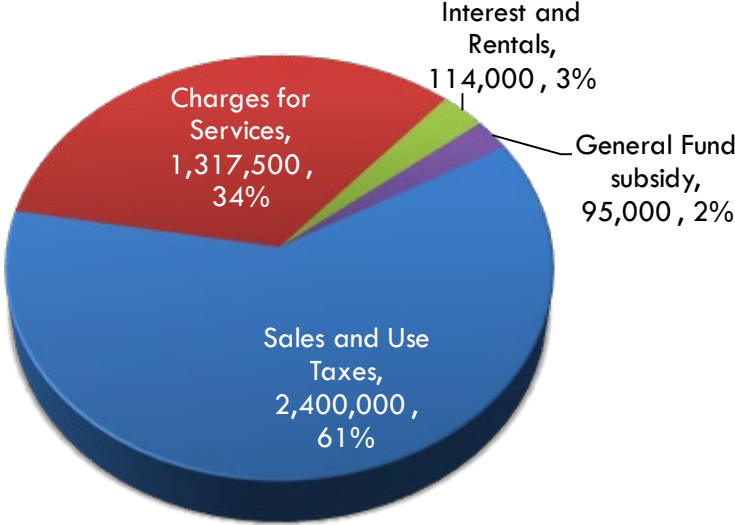

Quality of Place – Fruita Community Center Budget Highlights

- 2024 Revenues
 - User Fees
 - \$1 pass increase, expected to increase revenues around \$80,000.
 - First increase since 2017.

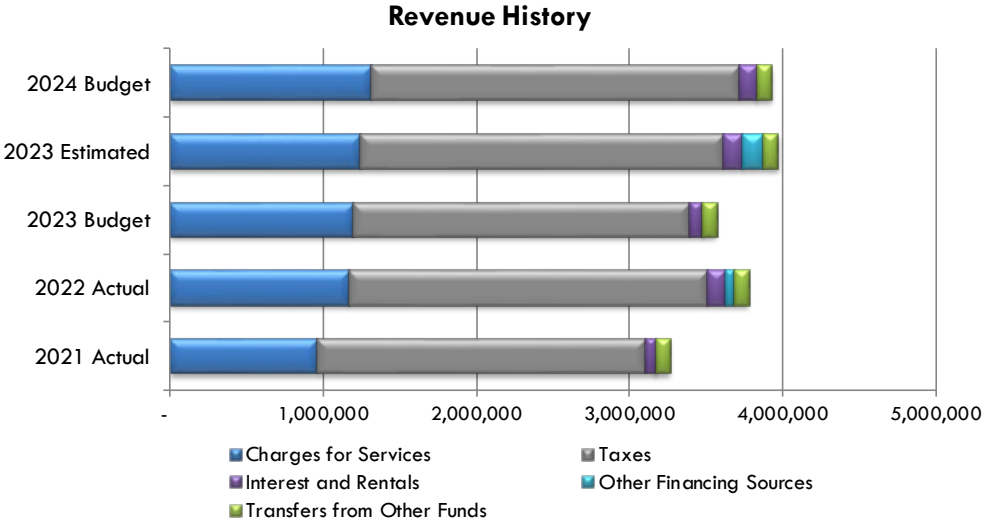

Quality of Place – Fruita Community Center Budget Highlights

- 2024 Expenses
 - \$4.3 million.
 - Decrease of 2% compared to estimated actuals (due to one-time expenses in 2023).

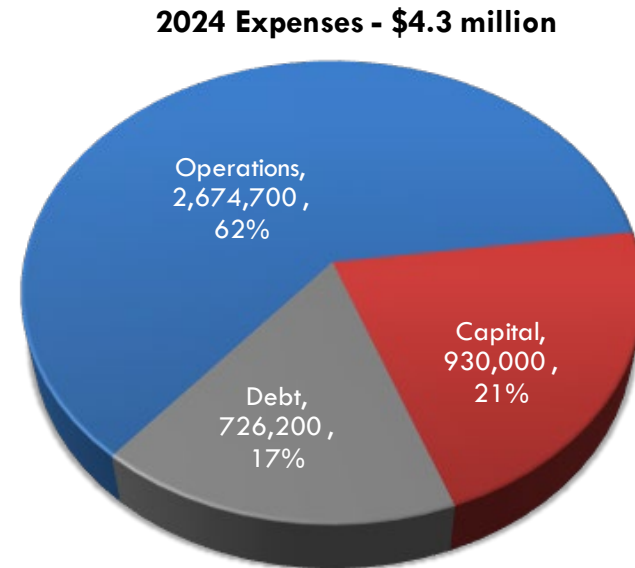

Quality of Place – Fruita Community Center

Budget Highlights

• **General Highlights**

- Personnel expenses to increase 21% over 2023 Budget due to two positions being assigned to FCC-Administration program.
- Supplies for resale are budgeted to increase 65% over 2023 due to success with a concession stand, from \$12,000 to \$20,000.

Quality of Place - Fruita Community Center Budget Highlights

- **Capital Expenses: \$930,000**
 - Indoor/Outdoor Pool Heater Replacement - \$100,000
 - Chemical Controllers - \$25,000
 - Fitness Program Replacement Equipment - \$60,000
 - Water Softener - \$15,000
 - Security Upgrades - \$30,000
 - Office Expansions - \$700,000



Quality of Place – Fruita Community Center Budget Highlights

- **Waterslide Update**
 - Construction drawings being finalized.
 - Current timeline – Construction early 2024, opening in March/April.

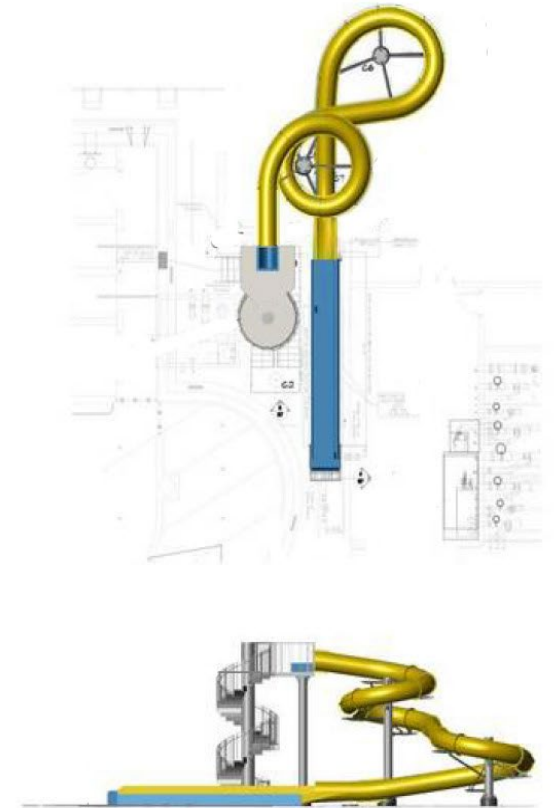
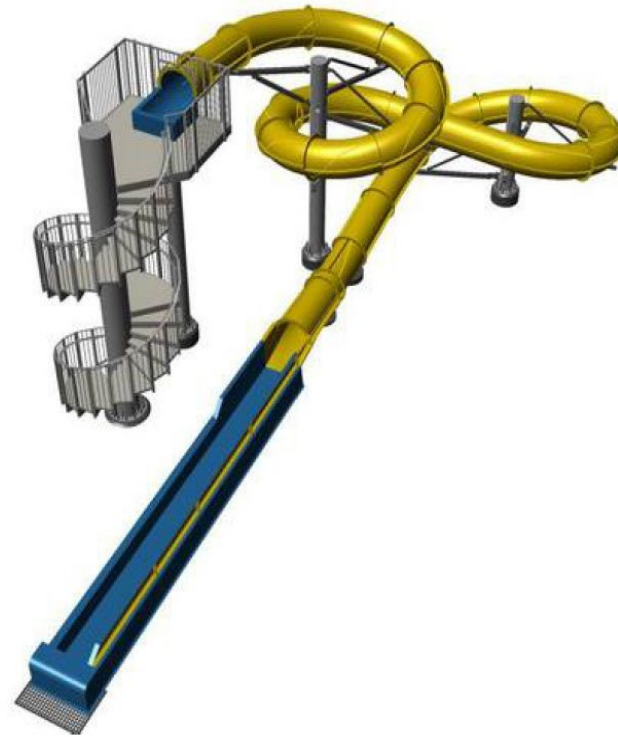

Quality of Place – 2024 Parks and Recreation and Public Safety Budget Highlights



Quality of Place – 2024 Parks and Recreation Expenses

- Notable Budget Changes

- Increased funding for entertainment at Fruita special events – additional \$9,000 (\$31,000 to \$40,000)
- Additional funding for Capital Equipment.
 - Irrigation repairs (\$65,000), MTHC costume (\$10,000), and soccer nets (\$2,500)
- Personnel expenses slightly decreasing due to minor changes to reflect time allocation.
- Budget to decrease slightly over 2023 Budget, 2% change.

Quality of Place – 2024 Parks Projects

- Amenities at the Fruita Bark Park \$35,000.
 - Includes:
 - Benches
 - Dog Agility Stations



Quality of Place – 2024 Parks Projects

- Install Vault Toilet at Snooks Bottom - \$100,000
- Design of the Colorado River Trail Underpass at Hwy 340 and the Colorado River - \$250,000



Quality of Place – 2024 Parks Projects



- **Reed Park Renovation**
 - \$2.1 Million Bid
 - Will be reappropriated from 2023
 - Expected completion Fall 2024
 - Budget amendment going to Council on November 21, 2023.

Quality of Place – Public Safety

- Budget Highlights
 - Increase funding for 911 Communications Center by \$40,000 for a total of - \$340,000
 - Replacement Police Interceptor - \$55,000
 - 2 New Police Computers - \$13,500
 - 7% increase over 2023



Personnel and Employee Retention

Budget Presentation

November 7, 2023



Personnel Overview

- Strategic Plan Goal: Be an Employer of Choice
- Employees continue to be our greatest asset for core service delivery.



Personnel Overview

- Personnel expenses are budgeted to increase 9% from 2023 Budget.
 - Salaries – 11% from actuals.
 - Benefits – 10% from actuals (which tend to be lower than budget).
 - Personnel services make up 58% of operating expenses.

2024 Expenses - Excluding Transfers

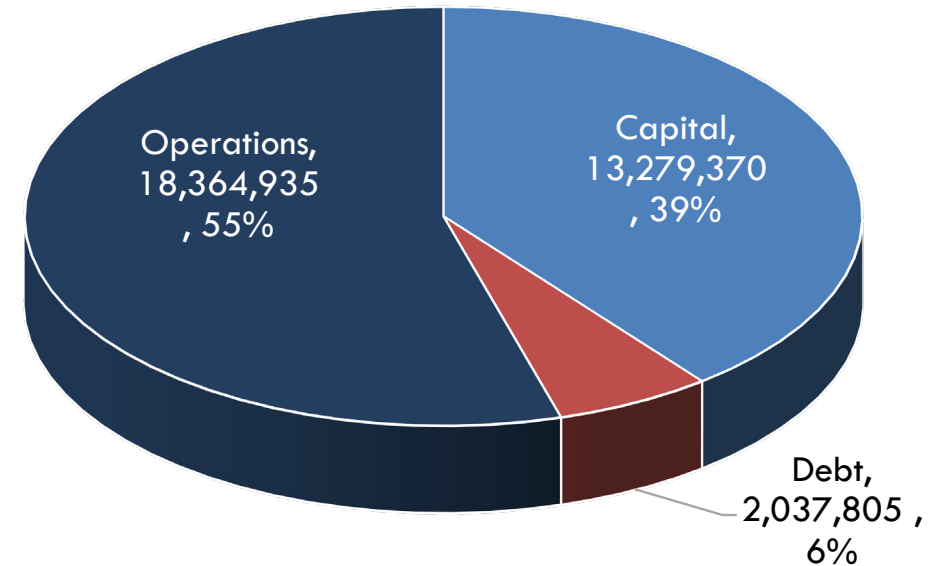

Wages and Salaries

Continued Implementation of Market-Based Pay Plan

- 8% wage increase from prior year.
- Employees earning an Exceeds Expectation will receive a one-time bonus.

Position Changes

- New Positions

- Finance Manager
- Procurement and Contracts Specialist
- Human Resources Analyst
- Public Works Maintenance Worker – Road Maintenance
- Parks Maintenance Worker
 - Approximate cost for conversions – between \$12 and \$25K.

Benefits Overview

- 2024 Changes
 - Health Insurance – 6.5% increase
 - Dental Insurance – 5% increase

CITY OF FRUITA



YOUR 2023 BENEFITS GUIDE



Retirement Contribution

- **No changes to the City's contribution for retirement.**
 - The City will contribute 4.5% to employee retirement plans.
 - Additional 1.5% if the employee also contributes.

Questions?

